

DWG. NO SB210-101A

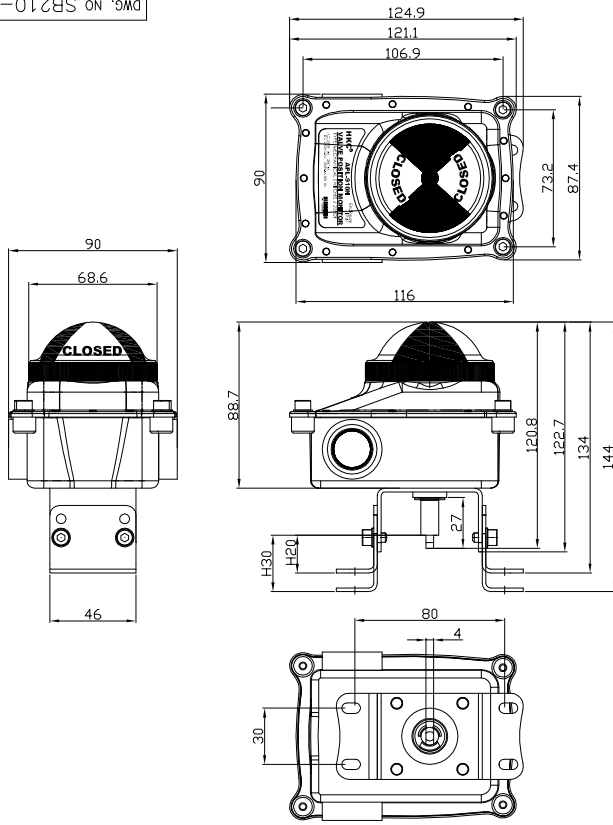

| NO | PART NAME | MATERIAL | Q.ty | REMARK |
|----|------------------|-----------------|------|--------------------|
| 1 | WINDOW/INDICATER | PC/ABS | 1 | |
| 2 | COVER | STAINLESS STEEL | 1 | |
| 3 | COVER BOLT | STAINLESS STEEL | 4 | |
| 4 | BODY | STAINLESS STEEL | 1 | |
| 5 | BODY BRACKET | STAINLESS STEEL | 1 | 80X30 H20,H30 |
| 6 | BRACKET BOLT | STAINLESS STEEL | 4 | |
| 7 | BRACKET | STAINLESS STEEL | 2 | 80X30 H20,H30 |
| 8 | SHAFT | STAINLESS STEEL | 1 | |
| 9 | CABLE ENTRY | STAINLESS STEEL | 2 | NPT1/2",M20,PF1/2" |

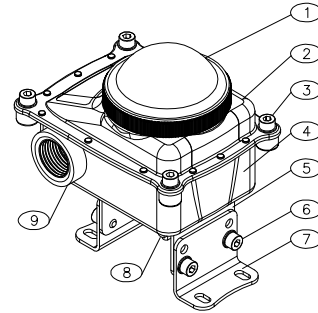

UNIT: mm

| PROJ. | SYM | ECN NO | CHANGES | DATE | SIGN | APPR. |
|----------------|---------------|-------------------------|--------------------|------------------------|---------------------------|-------|
| DRAW H.C. HONG | SCALE 1/1 | ISSU. DEPT.HADR | DATE 2016.03.23 | | | |
| DESIGN H.S.M | DIM. mm | PART NAME APL-9N LAYOUT | | BRACKET: 80X30 H20,H30 | | |
| CHECK S.I. BEE | HKC | | DWG. NO SB210-101A | | 1 OF 1 SHEET DWG. SIZE A3 | |
| APPR. S.M. HAN | HKC CO., LTD. | | | | | |

DWG. NO SB210-101B

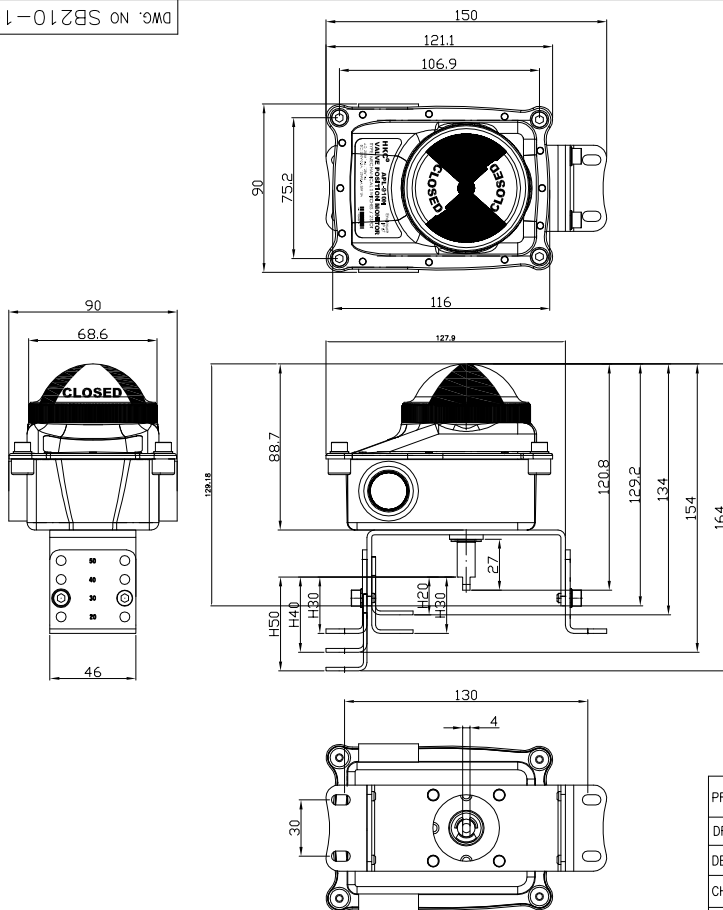

| NO | PART NAME | MATERIAL | Q.ty | REMARK |
|----|------------------|-----------------|------|-------------------------------------|
| 1 | WINDOW/INDICATER | PC/ABS | 1 | |
| 2 | COVER | STAINLESS STEEL | 1 | |
| 3 | COVER BOLT | STAINLESS STEEL | 4 | |
| 4 | BODY | STAINLESS STEEL | 1 | |
| 5 | BODY BRACKET | STAINLESS STEEL | 1 | 80X30 H20,H30 130X30 H30,H40,H50 |
| 6 | BRACKET BOLT | STAINLESS STEEL | 4 | |
| 7 | BRACKET | STAINLESS STEEL | 2 | 80X30 H20,H30 130X30 H30,H40,H50 |
| 8 | SHAFT | STAINLESS STEEL | 1 | |
| 9 | CABLE ENTRY | STAINLESS STEEL | 2 | NPT1/2",M20,PF1/2" |

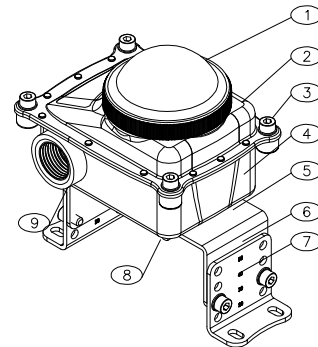

UNIT: mm

| PROJ. | SYM | ECN NO | CHANGES | DATE | SIGN | APPR. |
|----------------|---------------|-------------------------|--------------------|--|---------------------------|-------|
| DRAW H.C. HONG | SCALE 1/1 | ISSU. DEPT.HADR | DATE 2016.03.23 | | | |
| DESIGN H.S.M | DIM. mm | PART NAME APL-9N LAYOUT | | BRACKET: 80X30 H20,H30 130X30 H30,H40,H50 | | |
| CHECK S.I. BEE | HKC | | DWG. NO SB210-101B | | 1 OF 1 SHEET DWG. SIZE A3 | |
| APPR. S.M. HAN | HKC CO., LTD. | | | | | |