

NO	PART NAME	MATERIAL	QTY	REMARK
1				

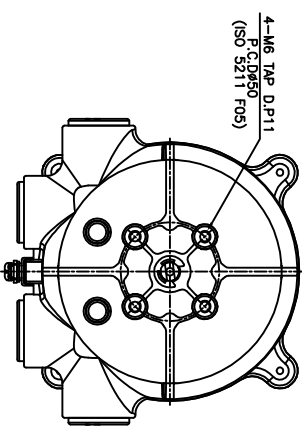
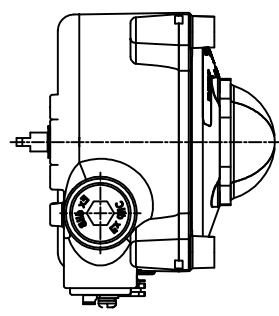
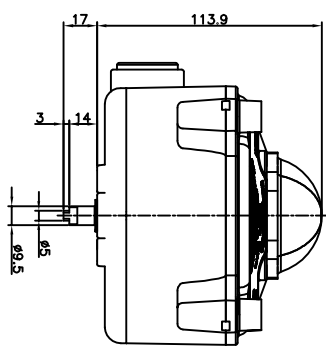
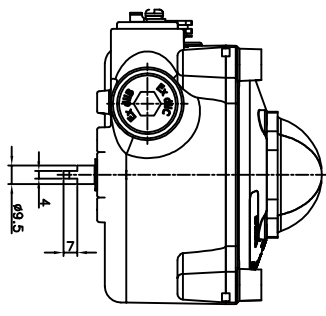
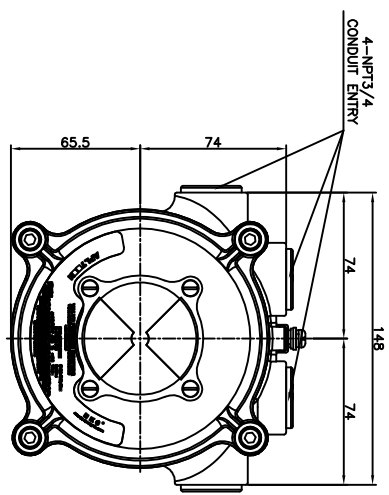

APPLICATION

UNLESS OTHERWISE SPECIFIED		MATERIAL		PROJ.		SYM		ECON NO		CHANGES		DATE		SIGN APPR.	
CLASS.	\ GR	1ST	2ND	3RD	4	SCALE	1/1	ISSU.	DEPT.	HADR	PART	NAME	DATE	2011.10.12	APL-8N
0.5 - 6	0.06	0.1	0.2	0.3	0.4	DIM.	TTT	DATE	2011.10.12						LAYOUT
6 - 30	0.1	0.2	0.3	0.4	0.5	CHECK	S.M.HAN								
30 - 120	0.15	0.25	0.35	0.45	0.55	APPR.	S.M.HAN								
120 - 315	0.2	0.3	0.4	0.5	0.6	HKC									
315 - 1000	0.3	0.4	0.5	0.6	0.7	HKC CO., LTD.									
1000 - 2000	0.5	0.6	0.7	0.8	1.0	1 OF 1 SHEET									
GENERAL TOL.		ANG. TOL.		GEN. CH. 0.5		SURF. TRET.		DWG. NO LB810-501-A		1 OF 1 SHEET		DWG. SIZE A2			